

© 2021 NTT DOCOMO, INC. All Rights Reserved.

# 5G Open RAN Ecosystem Whitepaper

June 2021



5G × Open RAN | OREC Official Site  
[https://ssw.web.docomo.ne.jp/orec/5g\\_open\\_ran\\_ecosystem/en](https://ssw.web.docomo.ne.jp/orec/5g_open_ran_ecosystem/en)

## Table of Contents

1.	5G Open RAN Ecosystem Overview .....	3
2.	Open RAN Benefits .....	4
2.1.	General.....	4
2.2.	Open Interfaces .....	4
2.3.	Virtualization .....	5
2.4.	Intelligence.....	8
3.	Open RAN Challenges and Solutions.....	10
3.1.	TCO (Total Cost of Ownership).....	10
3.2.	Integration and Interoperability Testing .....	12
3.3.	O & M (Operation and Maintenance).....	13
3.4.	RIC (RAN Intelligent Controller).....	15
3.5.	Security .....	16
3.6.	Performance and Deployment Scenario.....	18
4.	OREC Target Performance .....	21
5.	Future Prospects.....	22
6.	Conclusion .....	23
7.	Reference .....	24
8.	Annex A.....	26
9.	Annex B. Abbreviations.....	30

## 1. 5G Open RAN Ecosystem Overview

There is no end to the process of network augmentation, and current augmentation process needs to be further enhanced to better serve the future customer needs. To this effect, the networks should be flexible, agile and scalable. In addition, in the 5G era, creation of new vertical markets utilizing the mobile networks will be facilitated. Under these circumstances, operators need to keep evolving their networks by adding new network equipment and/or replacing existing equipment. With open interfaces and open application programming interfaces (APIs), operators can freely choose and adopt best-of-breed solutions among various vendors considering time-to-market and cost in this process by only adding or replacing the required components at the required time without having to swap other equipment that are connected.

NTT DOCOMO, INC. and other major global operators founded O-RAN ALLIANCE [1][2] in February 2018 [3] with the aim to promote open and intelligent radio access networks (RANs) in the 5G era. Since then, O-RAN ALLIANCE has been developing specifications and promoting implementation of products that allow operators to more freely combine disaggregated base station equipment.

DOCOMO has already deployed fully multi-vendor inter-operable RAN for 5G using the O-RAN open fronthaul interface [4] since the pre-commercial service launched in September 2019 [5], and has introduced different vendors in the same geographic area. New capabilities (mmWave, Sub 6 inter-band carrier aggregation (CA) [6]), radio unit (RU) types and central unit/distributed unit (CU/DU) vendor [7] have been introduced since then, and further, new RU vendors have been also selected.

DOCOMO also announced in February 2021 [8] that it had agreed with 12 companies — Dell Technologies Japan Inc., Fujitsu Limited, Intel K.K., Mavenir, NEC Corporation, NTT DATA Corporation, NVIDIA, Qualcomm Technologies, Inc., Red Hat, VMware K.K., Wind River and Xilinx, Inc. — to cooperate towards the “5G Open RAN Ecosystem” (OREC) with the objective to globally accelerate open RAN, and help enable flexible network deployment to serve diverse company and operator needs in the 5G era. In order to bring out good performance in open RAN, including virtualized RAN (vRAN), operators have to address certain challenges, and some of these challenges could only be resolved through interoperability testing. Considering these aspects, DOCOMO’s target is to package best-of-breed RAN and to introduce, operate and manage them based on demands from operators considering open RAN introduction. By leveraging its years of activities in driving open network and know-how, DOCOMO is committed to maximizing companies’ strength in furtherance of the OREC, and providing high-quality and flexible networks.

This white paper was developed taking into account the inputs from OREC participating companies regarding their views on open RAN and vRAN as well as their expectations for these ecosystems. These inputs are captured in Annex A of this white paper.

## 2. Open RAN Benefits

### 2.1. General

The transformation of radio access networks by open RAN is driven in three main technical areas:

1. Open interface realizing mix-and-match of RAN equipment from different vendors
2. Virtualization allowing disaggregation of RAN equipment hardware and software
3. Intelligence driving optimization and automation of RAN operations.

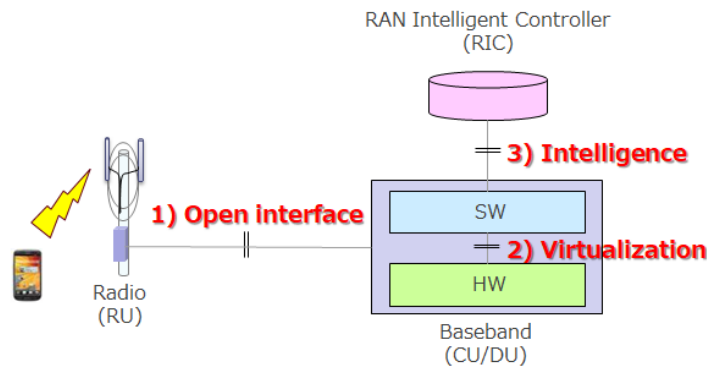

Figure 2-1 Technical areas of open RAN

In terms of commercial realization, open interface having higher maturity of O-RAN specifications and product implementations is a bit ahead. Virtualization and intelligence are also just around the corner with various PoCs ongoing and commercial vRAN products starting to get deployed globally. Collectively, open RAN will enable communication service providers (CSPs) to be free from vendor lock-in and to adopt best-of-breed solutions for providing optimized services to end customers with shorter time-to-market. Open RAN is also expected to foster sustained innovation and create a diversified and vibrant supplier ecosystem. All of this is vital for the RAN industry to meet the diversifying demands and to support the increasing complexities of the mobile system.

### 2.2. Open Interfaces

With open interfaces, it becomes possible to mix-and-match RAN equipment from various vendors. This allows to introduce and utilize optimal RAN equipment depending on the deployment scenario considering performance, supported features, schedule and cost.

The most prominent is the open fronthaul interface specified by the O-RAN ALLIANCE. For example, with the open fronthaul, best radio units (RUs) for each frequency band and deployment scenarios, e.g. indoor, outdoor micro and outdoor macro, can be chosen regardless of the baseband unit (CU/DU) vendor. Also, CU/DU can be replaced with those

providing better performance, e.g. capacity and power consumption, without having to swap already deployed RUs. Furthermore, as any vendors' RUs and CU/DUs can be selected, cost competitiveness can be improved. As such, continuous network augmentation utilizing best-of-breed products with reduced costs becomes possible.

The O-RAN ALLIANCE also specifies profiles for 3GPP RAN interfaces to achieve interoperability among different vendors. So far, profiles for open X2, open Xn and open F1 interfaces have been published. Open X2 enables operators providing 5G Non-StandAlone to introduce 5G NR base stations (gNBs) independently of the vendor providing 4G LTE base stations (eNBs). Similarly, open Xn allows operators providing 5G StandAlone to introduce gNBs from different vendors in the same geographical area. Open F1 provides similar multi-vendor benefits as the open fronthaul but at the higher layer split between CU and DU.

### **2.3. Virtualization**

Most web application services are migrating to the cloud. In telecom infrastructures, cloud migration is advancing in core networks, and cloud computing is also gradually happening toward the edge. Similar to the core networks, RAN services currently realized by dedicated software on hardware are considered to be realized by RAN applications running on Commercial Off-The-Shelf (COTS) servers.

In general, virtualization brings the following benefits:

- By separating hardware and software, leading-edge hardware can be easily introduced.
- Latest technology can be introduced only by updating software.
- The latest and many technologies from the IT industry can be introduced.
- Improved development efficiency and shorter time-to-market by leveraging open source and general-purpose communities

Looking at the mobile domain, virtualization has been introduced in the core network by many operators including DOCOMO. The benefits which have been obtained with core network virtualization are shown in Figure 2-2 – 2-5.

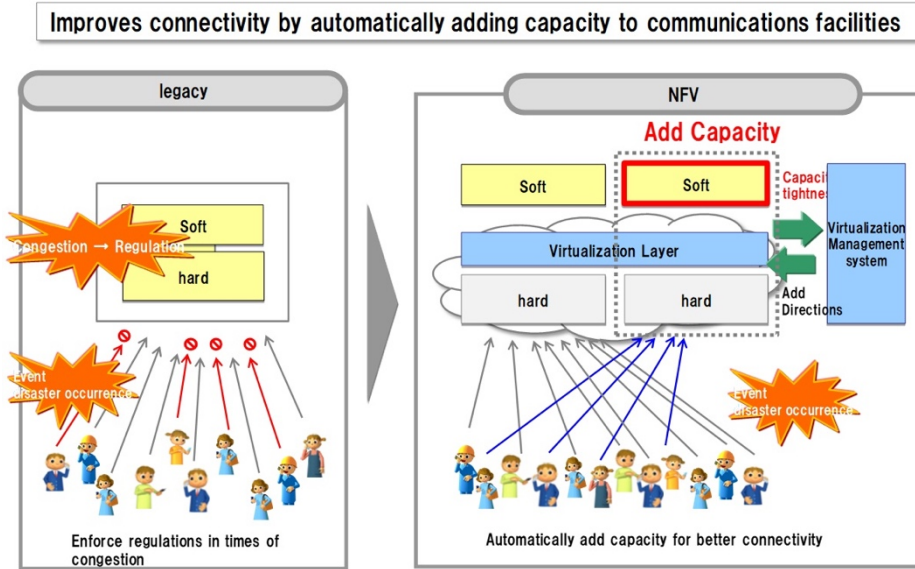

**Figure 2-2 Improvement of connectivity in case of congestion (scale-in/out)**

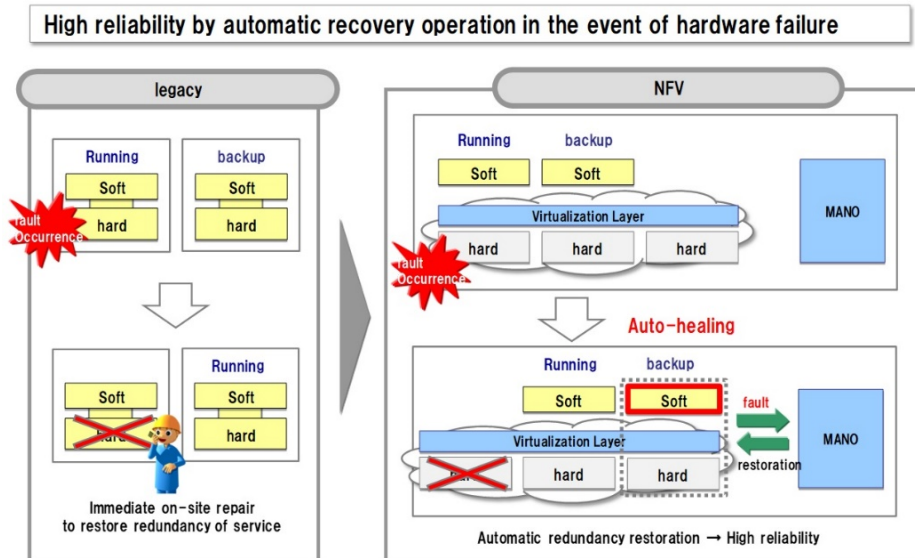

**Figure 2-3 Improvement of reliability of communications services (auto-healing)**

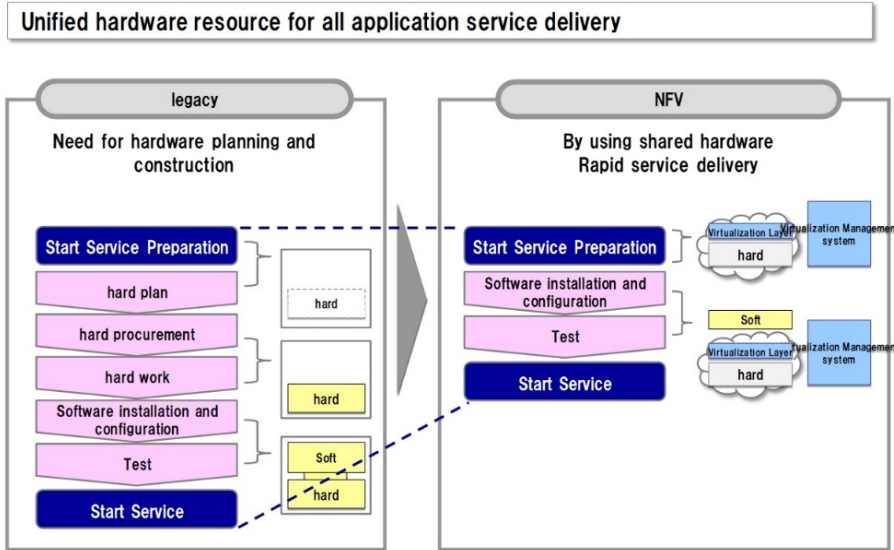

Figure 2-4 Improvement of agility in service delivery

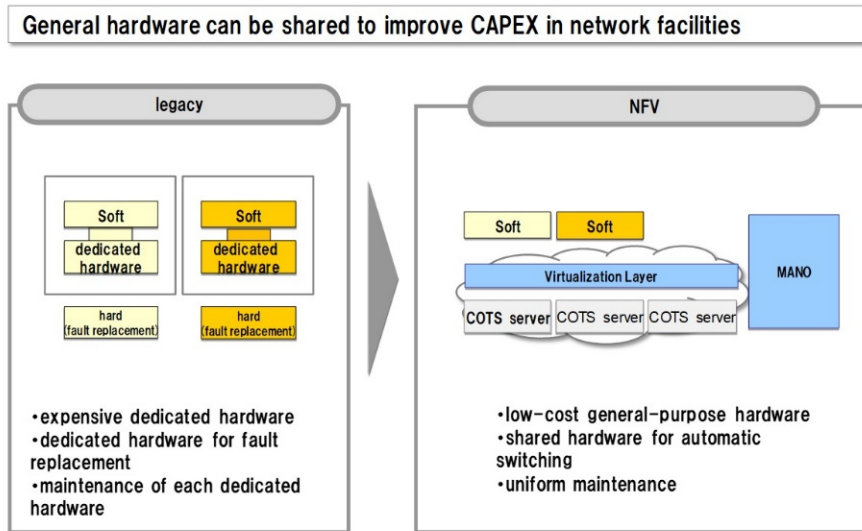

Figure 2-5 Economical Network (CAPEX and OPEX reduction)

By bringing virtualization to RAN, the following benefits can be expected:

1. Best-of-breed RAN solutions by disaggregating software and hardware
  - Avoid vendor lock-in (existing RAN node is tightly/vertically integrated)
  - Reduce CAPEX/OPEX by leveraging COTS hardware
  - Increase extensibility of RAN services by RAN software upgrade
  - Improve performance with the latest generation hardware platform
  - Bring deployment flexibility
2. Simplified and intelligent RAN operations by virtualization and automation technology
  - Leverage NFV technology (e.g. scale-in/out and auto-healing)
  - Realize RIC and Zero-touch provisioning

### 3. Share infrastructure and operations from edge to core (as shown in Figure)

- Common infrastructure and operations across RAN, CN and MEC
- Unified life cycle management of virtual resource and application

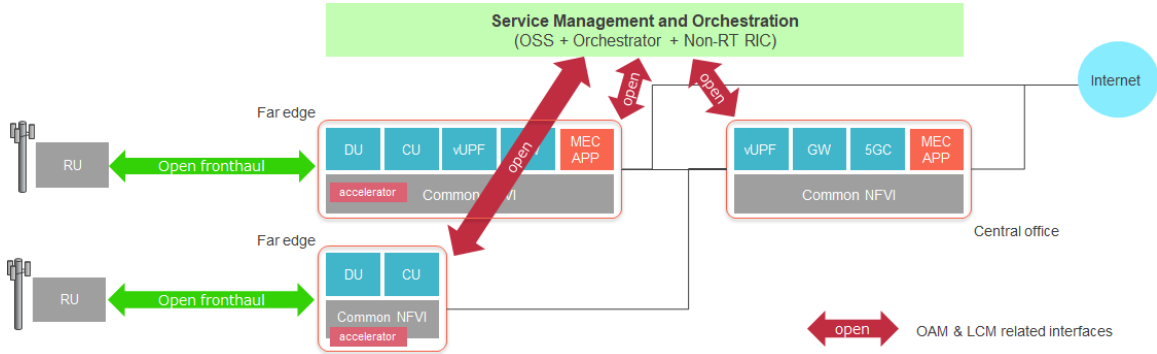

Figure 2-6 Common infrastructure and operations across RAN, CN and MEC

## 2.4. Intelligence

Deployment and operation of RAN in the 5G era is becoming complex due to various use cases and applications supported in a network as well as diverse combinations of network parameters and configurations. Furthermore, introduction of split architecture and virtualizations will increase the complexity of RAN. Under these circumstances, it has become increasingly difficult to manage RAN deployment and operations as well as to achieve RAN optimization with traditional manual operations. In order to solve this issue, introduction of intelligence in RAN is inevitable, enabling automated management and control by using big data analysis, artificial intelligence (AI) and machine learning (ML).

From the operators' perspective, one of the important benefits of introducing intelligence is to reduce OPEX through digital transformation in the RAN operation, which reduces associated operational activities and cost such as drive tests, manual configuration and optimization. Another important benefit is improved RAN performance through automated optimization of radio resource management and control, which will contribute to improvement of customer satisfaction and creation of new businesses.

In order to realize the above-mentioned intelligence in RAN, O-RAN ALLIANCE is leading the mobile industry activities for ecosystems development with regard to innovative, multi-vendor, interoperable and autonomous RAN. RAN Intelligent Controller (RIC) is a key technology to provide intelligent radio resource management and optimization by using the AI/ML models. RIC includes two layers; non-real-time (non-RT) RIC with a control frequency over 1 second and near-real-time (near-RT) RIC with a control frequency below 1 second.



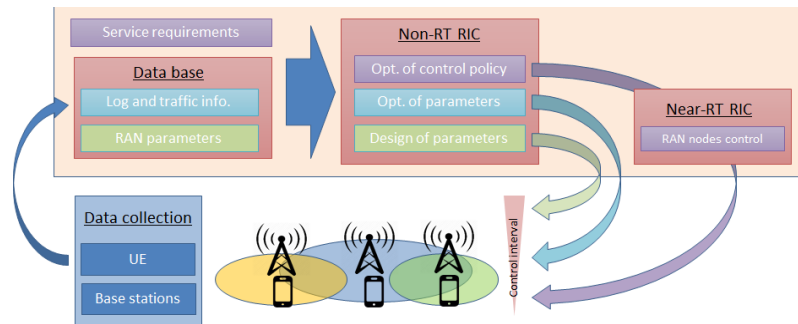

**Figure 2-7 RAN Intelligent Controller**

RIC is implemented by decoupling its platform and software applications, which are connected through open interfaces being developed by O-RAN ALLIANCE. Because of the open interfaces, development of software applications such as managing of control policies and/or actions to RAN nodes is not limited to RAN vendors, but is open to operators and third-party vendors. This feature is also an important benefit of open RAN.

### 3. Open RAN Challenges and Solutions

#### 3.1. TCO (Total Cost of Ownership)

Lower Total Cost of Ownership (TCO) has been expected by introducing open RAN and vRAN. Open RAN brings cost benefits as multi-vendor interoperability allows operators to select products from any vendor, and to make the best choice also from cost perspective. For example, with the open fronthaul, operator can select the most cost competitive RU from multiple vendors without being restricted to the CU/DU vendor.

Also, RAN virtualization is considered to provide cost benefits by aggregation of hardware at centralized locations and use of general purpose servers. On the other hand, vRAN also has factors which can increase the cost. For example, vRAN introduces a new virtualization layer between the hardware and software in which itself is an increased cost, and additional costs for troubleshooting are also anticipated. In determining whether/how to introduce vRAN, brownfield operators also need to consider (a) investments already made for and (b) interoperability with their existing networks.

Therefore, whether/how cost benefits can really be enjoyed must be carefully determined. In this section, we will discuss the major challenges in terms of TCO for realizing vRAN/open RAN.

#### **Major CAPEX factor**

##### Hardware investment

When full-fledged 5G deployment is realized and the numbers of frequency bands and MIMO layers increase, it is easy to imagine that the computational complexity of signal processing will increase exponentially and the power consumption of equipment will increase. With the conventional vRAN, high-speed control of the physical layer required for virtualized base station equipment (vCU/vDU) cannot be realized, and as a result, dedicated hardware is used to achieve the required performance.

For operators to realize vRAN, it is necessary to improve energy efficiency by making good use of accelerators and to satisfy requirements as RAN while suppressing the cost of computational resources. Here, it is considered that the performance truly required for vRAN, which could not be realized in the past, can be realized by incorporating accelerators for vCU/vDU. Approaches to utilize hardware accelerators are discussed in later chapters.

##### Software investment

One of the challenges of introducing RAN virtualization is that investment in the virtualization layer (virtualization platform) is essential. Various vendors sell virtualization platforms as commercial products, but operators will always be charged the cost of using this platform at the time of construction and on an ongoing basis if they operate vRAN.

However, as touched on later in the challenge of OPEX, introduction of the virtualization platform makes it more cost-effective for operation and maintenance. Approaches to these challenges will be discussed in later chapters.

### **Major OPEX factor**

#### Operation and maintenance labor cost

In a virtualized environment, multiple servers can be centrally managed by software, thereby producing the benefits of suppressed cost for maintenance and operation. For example, with the automated healing and scaling enabled by virtualization technology, virtualized servers can be quickly expanded and shrunk as needed within the pooled resources, thereby reducing the number of on-site maintenance personnel. The transition to a virtualized environment will inevitably require a review of monitoring mechanisms and failure response flows. However, by utilizing the know-how related to network control, operation, and optimization that operators have cultivated so far to formalize operation and management process with virtualization technology will lead to the opportunity for enjoying the OPEX reduction benefits of virtualization.

#### Integration cost

Testing with multi-vendor products is also challenging. Building an end-to-end solution with multi-vendor products involves appropriate testing which requires skillset and know-how. In addition, virtualized products have shorter lifecycles requiring testing and migration at each cycle. To address such testing and integration challenges, we have launched the OREC and will provide a testbed with remote access capability in which global operators considering the introduction of open RAN can freely use the vRAN verification environment. This could be an effective way to share and reduce testing and integration costs. Challenges and solution for integration will be discussed more thoroughly in a later chapter.

#### Electricity cost

In addition, if vRAN is expected to become full-scale and the number of frequency bands and MIMO layers will increase, it is easy to imagine that the amount of calculation for signal processing will increase proportionally and the power consumption of the device will increase.

In general, dedicated hardware consumes less power compared to general-purpose servers. On the other hand, general-purpose hardware has achieved low power consumption with each new generation and hardware accelerators with low power consumption also exist. As an operator, the solution approach to this issue is to realize a flexible system configuration that can take in new hardware. Approaches to these challenges will be discussed in later chapters.

Open RAN and vRAN is expected to bring cost benefits. Several challenges for vRAN were highlighted. In OREC, we intend to address those challenges and study appropriate configurations which make sense from TCO perspective for various deployment scenarios, and further to pursuit technologies to reduce vRAN costs such as cost effective hardware and utilization of RIC to reduce power consumption.

### **3.2. Integration and Interoperability Testing**

Separating base station equipment into multiple components (RU, DU and CU) based on the open RAN concept allows operators to select products with flexibility. However, this flexibility makes it necessary for the operators to properly select and integrate the products. It is also necessary to confirm that required functions and performance are properly achieved through a verification test process.

Even when vendors implement open interface according to the specification defined by the standard organization such as 3GPP and O-RAN ALLIANCE, interpretation of the new specifications may be sometimes different among vendors. Therefore, until the specification becomes stable, verification through interoperability testing to connect different vendors' products is important. When a product manufactured by a new vendor is adopted, the interoperability testing needs to be completed individually.

Verification process consists of establishing testbed, designing the contents of verification, and performing a testing with products from vendors. Test cases are increased according to the number of open interface and the number of vendors.

In order to solve the above challenges, DOCOMO will establish open testbed for OREC in Japan. One of the main feature of the testbed is to be remotely controlled from the operators as if the testbed is located in their lab. In other words, operators can use the testbed regardless of locations where the operators are. Furthermore, by connecting the testbed to the target operator's core network, they can easily test vRAN with multiple vendors with their network. Thus, operators will enable dramatic reduction of time and cost. The testbed is scheduled to launch in the summer of 2021, and products by OREC partner will be available during the third to fourth quarters of 2021.

DOCOMO has been providing commercial services with fully inter-operable multi-vendor RAN before 5G era, thereby accumulating experience and know-how of interoperability testing between equipment from different vendors. In addition to the experience and know-how, experience and know-how in end-to-end performance evaluation testing have been well accumulated. For example, DOCOMO has enough experience and know-how about performance tests assuming mobile communication environments, tests under high-load environments assuming urban areas such as in Tokyo, test assuming rural areas, and so on.

Therefore, in addition to the verification to ensure the interoperability with multi-vendor RAN, the testbed will be able to test the performance including throughput, mobility and stability under the various type of environment assuming the commercial network.

In O-RAN ALLIANCE, Open Test and Integration Center (OTIC) is being discussed to test and verify the conformity of equipment with O-RAN specifications and the interoperability of equipment from different vendors (or the same vendor) using O-RAN specifications, and to conduct functional as well as performance tests of end-to-end systems. These tests are based on test requirements specified by O-RAN ALLIANCE. In other words, the verification conducted by OTIC does not include the contents specific to the operators. On the other hand, in our testbed, it is also possible to verify the contents customized for the operators. Our testbed and OTIC are complementary, and together they will promote the acceleration of open RAN.

One of the other challenges considered as the integrity and interoperability is concerning the responsibility for the integrated equipment. As mentioned above, open RAN allows combination of products manufactured by different vendors; therefore, when improving end-to-end performance or resolving unexpected end-to-end troubles, it is necessary to clarify which components should have the responsibility to do. Another challenge is the need for clarifying equipment procurement methods. For example, it needs to clarify whether the operator procures products for each component, or whether the operator procures only the integrated equipment, and so on. DOCOMO is planned to collaborate with OREC partners to resolve these challenges.

### **3.3. O & M (Operation and Maintenance)**

#### **Introduction**

Open RAN including vRAN has many potential benefits and are gaining traction. However, for deployment in commercial networks, they require O&M to be in place.

Service Management and Orchestration (SMO) is the critical management component in the O-RAN architecture. SMO hosts functions such as RAN application management, vRAN infrastructure (O-Cloud) management, and RIC.

The O-RAN ALLIANCE promotes realization of multi-vendor network by specifying O1 and O2 interfaces between SMO and RAN applications and between SMO and O-Cloud, respectively.

To implement vRAN with SMO in commercial network, it requires reasonable SMO decomposition matching operator requirements on management system configurations and appropriate O1/O2 interface specifications to support vRAN application and infrastructure from multiple vendors.

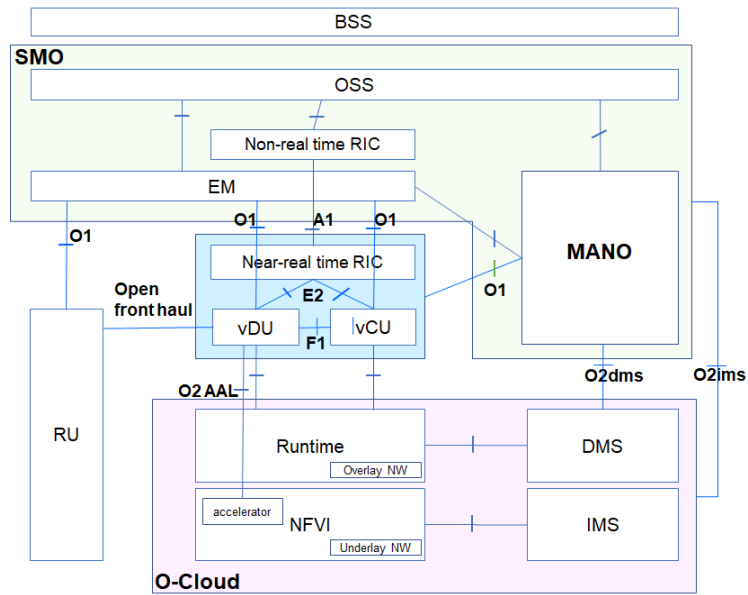

Figure 3-1 DOCOMO's view on vRAN architecture

### SMO realization

In O-RAN specifications, management-related components are grouped together as SMO. In practice, however, features such as RAN application management, O-Cloud management and RIC functionality will need to be realized as subcomponents within the SMO.

DOCOMO will work with OREC partners' products to realize these SMO sub-components. Our view is that it consists of Operation Support System (OSS) and Element Management (EM), Management and Network Orchestration (MANO) and Non-realtime RIC subcomponents.

### Automation with vRAN

The existing RAN system consists of dedicated equipment and requires support personnel to go to the site for construction, modification and recovery work.

Operational costs and work time can be reduced by decreasing the frequency of on-site work and increasing automation by software. Virtualization helps to achieve this by disaggregation of hardware and software with more features being implemented by software, and by intensive use of automation realized by MANO.

MANO controls each software component to automate the construction, modification, and recovery of the vRAN system consisting of multiple vendors. Such control is expected to be performed via the O1 and O2 interfaces. The automation by MANO can be expected to significantly shorten the construction period.

At the OREC testbed, we will perform IOT for O1 and O2 interfaces, and verify vRAN automation from MANO within the SMO for multi-vendor systems. This will enable the automation of operation and maintenance for open and multi-vendor vRAN systems. The

activity also intends to address practical issues for operators such as connection with existing OSS and operation on existing cloud infrastructure.

### **Standardization for telecom grade vRAN**

The vRAN system must enable interoperability between components (SMO including MANO, vRAN applications and O-Cloud) of different vendors by making the O1 and O2 interfaces open. DOCOMO will contribute to O-RAN specification work and will promote integration that can withstand commercial operation through the OREC testbed.

RAN is also increasingly dependent on and realized by software in conjunction with virtualization, and especially for virtualization platforms, de facto open-source software is available.

Taking-in open source is also being considered for the O2 interface. However, de facto open-source software frequently adds functions and improves performance, leading to the situation where the API and implementations can be significantly different between open-source software versions. Therefore, the O2 interface should be specified with appropriate modeling with well-defined orchestration use cases and functions split of each component (e.g. O-Cloud and SMO) to enable multi-vender operation and to minimize non-backward compatibilities. ETSI-NFV follows the same principle and how to align with/leverage their work should also be considered.

DOCOMO will carry out system integration in a multi-vendor configuration with OREC partners at the testbed, and intends to contribute the findings to O-RAN specification for vRAN.

## **3.4. RIC (RAN Intelligent Controller)**

RIC will enable RAN automation and optimization in a wide range of use cases to provide enhanced services in a network as well as improved user experience by using the AI/ML workflow. O-RAN ALLIANCE has been developing specifications for many RIC use cases.

In our view, intelligence in RAN through RIC implementation will be realized in a stepwise manner taking into account complexity of required controls, impact on the existing assets of RAN nodes and progress of the relevant specification development by O-RAN ALLIANCE. We also believe that close collaboration between operators and vendors is essential for creating the ecosystem comprising the O-RAN ALLIANCE-compliant RIC products.

Figure below shows our consideration on a roadmap for certain RIC use cases to be supported by intelligent RAN. In the roadmap, initial target use cases are mainly for reduction of RAN operational cost; and then the use cases are further expanded to enhance RAN performance and customer satisfaction where control schemes are enhanced in a step-

wise manner (e. g., from slow control to fast control, and from per-cell control to per-user control).

Furthermore, utilization of RIC, for example, dynamic control of base stations' transmission power as well as use of base band resources, like normal mode and energy-saving mode, in accordance with prediction of traffic loads, can contribute to reduction of power consumption in RAN, which will be an essential aspect towards realization of a carbon neutral society.

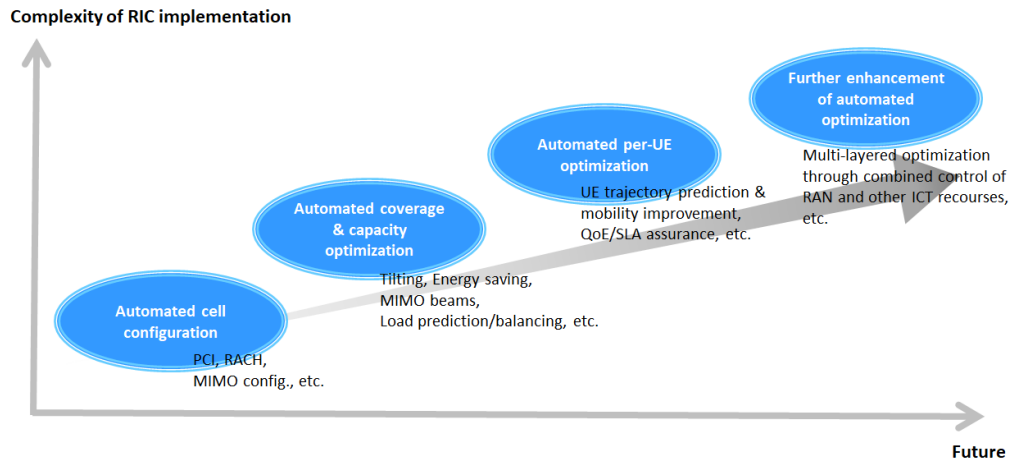

**Figure 3-2 Roadmap of RIC-enabled use cases**

Introduction of RIC in RAN is also in line with the concept of Cognitive Foundation® [9] for the Innovative Optical and Wireless Network (IOWN), which will achieve optimal harmonization of all ICT resources.

### 3.5. Security

Open RAN brings several enhancements leading to increased modularity combined with increased functional split, utilization of open source and commonly used protocols, interface to third parties and use of cloud. In the following we discuss potential security challenges, security opportunities, solution directions and recommendations for open RAN.

Security challenges associated to open RAN can be presented in the form of technical, process and people. Technical security challenges, see Figure 3-3, are (1) security issues that arise in open source software and off-the-shelf technologies, (2) more exposed interfaces (user, control and management) that leads to increased threat surface, (3) security issues associated to various RAN functions including those newly introduced by the O-RAN ALLIANCE, (4) functional split that brings large number of edge computing in picture leading to higher probability of physical security attacks, (5) cloud associated security issues in the form of hardware & software split, orchestration associated security issues and utilization of multiple parties which is also a characteristic of increase in



modularity. Process related issue will mainly come from network operators not having appropriate security process for complete lifecycle of open RAN deployment which brings several changes to existing operating model. People related issues will appear in the form of lack of resources and experience.

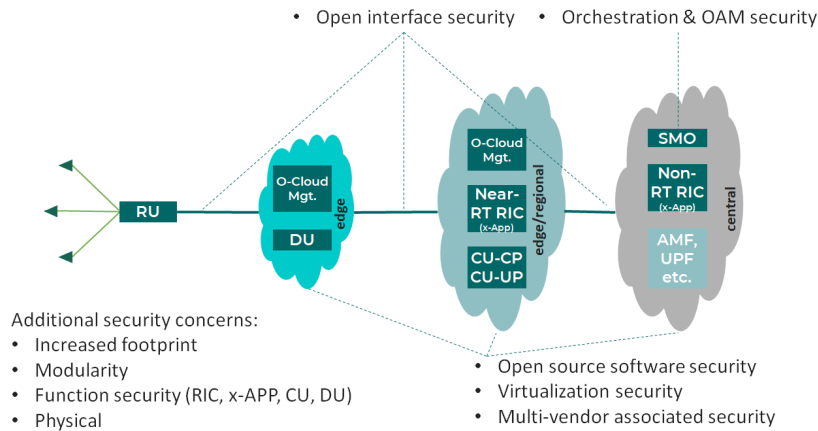

**Figure 3-3 Open RAN security challenges**

Looking at the security challenges it is obvious that most of them are neither new nor specific to open RAN. Potential security solutions associated to the challenges are first and foremost to bring holistic security in place that encompasses security by design and zero trust. A key item of holistic security, Figure 3-4, is consideration for complete lifecycle where baseline security (such as hardening, password management) and asset as well as identity & access management (IAM) together with privileged access management (PAM) play a key role. Lifecycle security also includes appropriate consideration for continuous security in context of CI/CD, DevOps and agile method of working. Continuous security in the form of vulnerability management should be applied to production network as well. Interfaces can be secured with security credentials provisioned to the functions that are the end-points of the interfaces and by utilizing existing security protocols. Network operators should take care that there is clear separation of roles defined among vendors, infrastructure providers and service providers where each party takes care of their share of security. In addition open RAN calls for shift in mindset related to security architecture since cloud and edge are heavily used. Last but not least, proper considerations for security operation becomes essential with considerations for automated monitoring, response and operations (AMOR). In terms of processes and resources, IT security process can form the foundation and resource issues can be resolved by automation as well as utilization of IT security resources since the technology is very similar.

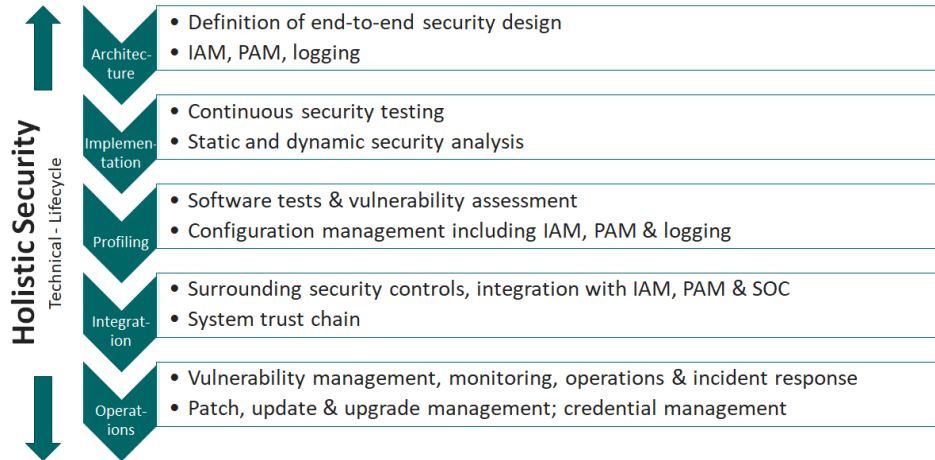

**Figure 3-4 Holistic security for technical challenges**

Every new solution brings new security challenges. Certainly something to the scale of open RAN has to bring additional security issues but at the same time open RAN brings new opportunities in the form of (1) greater control to network operators in terms of security, (2) opportunity to mix and match best in bread of security solutions, (3) possibility for very fast fixing of any security issues without impacting production network or services, (4) increased visibility in place allowing better operations and response to incident, (5) greater automation possibility and (6) potential to use well established IT security processes as well as resources.

These security opportunities together with recommendations for open RAN not only provides solutions for the security challenges but takes the overall security level far beyond anything existing today.

### 3.6. Performance and Deployment Scenario

As was beneficial for the core network, virtualization is also attractive for the radio access network (RAN). However, there are some challenges for virtualization that are specific to the RAN such as more stringent performance requirements and more distributed deployment scenarios. These challenges are described in this section. Addressing these challenges will enable wide adoption of vRAN in many operators' network.

#### Performance improvement

As a major difference from the virtualization of core networks, the packet processing of radio systems requires real-time processing on the order of  $\mu\text{sec}$ . Because such processing requirements are difficult to be realized only by CPUs, especially for the most demanding scenarios (e.g. 5G with 100MHz or more bandwidth and/or large number of MIMO layers), hardware accelerators will be required to offload L1 processing (partially or fully). Currently, various hardware accelerators such as FPGA, GPU and ASIC are being

developed. Each has its own characteristics and may be considered as viable options to serve a variety of deployment scenarios.

### **Handling of multi-domain network function**

One of the exemplary scenarios of vRAN is to be able to run multiple 5G workloads efficiently in a single RAN equipment. These workloads could be DU/CU, RIC, UPF or even MEC applications, blending elements of the core and access networks together in a flexible way to realize optimal performance as shown in Section 2.3. In this case, however, there could be difficulty to some extent in securely isolating one workload from others while conforming to stringent 5G computational requirements as well as SLAs associated with applications to concurrently run.

### **Deployment scenario**

If introduction at Data Centers (DCs) is possible similar to core networks, it is likely that hardware resource pooling will be possible and will provide the same benefits as core networks as discussed in Section 2.3.

In case of base station equipment, they are not only installed at DCs as in the case of core networks, but also at distributed locations (e.g. in limited floors in small buildings, at outdoor sites right under the antenna). So sufficient hardware resource pool may not always be available. While aggregation benefits may be reduced in such cases, the cost savings of migration from dedicated hardware to general-purpose hardware and the benefits of separation of HW and SW are still available. By introducing RAN disaggregation with Higher Layer Split (HLS), i.e. CU-DU split, it may be easier to at least aggregate the CU for larger HW resource pooling at the DC.

Further, by establishing a common infrastructure with applications such as MEC, there is a possibility of providing added value in addition to reduced hardware cost.

### **Flexibility and scalability**

As described above, base station equipment can be installed in different locations, and the performance and capacity required at each location are different. Therefore, flexibility of infrastructure configuration is required to support various use cases. This may be achieved by enabling flexible and scalable support of hardware accelerators (type and number) as needed. Further, recent efforts toward zero emission are urgent, and such flexibility will also help ensure that new hardware with high performance and low power consumption can be adopted as they emerge. When changing hardware accelerators, it is desirable to minimize impact to RAN software, and Accelerator Abstraction Layer (AAL) work in O-RAN WG6 is important with this regards.

The OREC partners have already potential solutions for the challenges mentioned above. Also, DOCOMO has already introduced virtualization in the core network and have many experiences regarding multi-vendor commercial network operation. By combining each

partners' innovative technologies from both software and hardware and DOCOMO's experience, we plan to develop commercial-ready vRAN meeting operator's requirements through OREC activities. Also, we intend to contribute the findings from OREC to O-RAN WG6 standardization work.

## 4. OREC Target Performance

High performance is required for vRAN to be widely adopted in commercial network. For example, if the achievable capacity by vRAN is decreased compared to current traditional RAN, the required number of equipment to deploy increases and the vRAN may be less cost effective. So at least the same level of performance as that of the traditional RAN used in the current network is needed.

DOCOMO's target performance for vRAN in OREC is shown in the table below compared with current vRAN performance. Based on the input from partners, these values should be achievable in a year and we believe they can also exceed current gNB performance installed in many operators.

**Table 4-1 OREC Target Performance(Comparisons with today's vRAN performance)**

<b>Performance criteria</b>	<b>Target</b>
Max number of Cells per server (Massive-MIMO 64T64R, 16DL8UL)	3x or more
Max number of cells per server (SU-MIMO 4T4R, 4DL2UL)	3x or more
DL Throughput	3x or more
UL Throughput	3x or more
Power consumption	1/2x or less

## 5. Future Prospects

In Chapter 2, we discussed that adoption of open RAN has various benefits. On the other hand, as we explained in Chapter 3, there are some key challenges for operators to introduce open RAN. We believe OREC will help the open RAN ecosystem expand and thrive by providing solutions for those challenges as discussed in Chapter 3 and meeting target performance stated in Chapter 4.

As the open RAN ecosystem grows, telecom industry will be benefiting from other various kinds of industries. For example, key players and growing startups in the IT industry are entering the area of virtualization and intelligence with their strengths and technologies.

In the future, the open RAN ecosystem may evolve and merge into an overall ecosystem of telecommunications and IT infrastructures by sharing servers and virtualization infrastructures with transport networks, core networks and IT systems. In other words, we need to look at the entire ICT infrastructures and consider future vision and migration. In our view, activities in OREC will lead to the concept of IOWN, which will achieve optimal harmonization of all ICT resources.

## **6. Conclusion**

This whitepaper introduced our considerations and efforts on the 5G Open RAN Ecosystem (OREC). DOCOMO will collaborate with a wide range of stakeholders, including OREC participating companies, to advance the ecosystem and to contribute to the industries.

## 7. Reference

[1]

O-RAN: Towards an Open and Smart RAN, O-RAN ALLIANCE, October 2018, available at <https://static1.squarespace.com/static/5ad774cce74940d7115044b0/t/5bc79b371905f4197055e8c6/1539808057078/O-RAN+WP+Final+181017.pdf>

[2]

O-RAN Use Cases and Deployment Scenarios towards Open and Smart RAN, O-RAN ALLIANCE, February 2020, available at <https://static1.squarespace.com/static/5ad774cce74940d7115044b0/t/5e95a0a306c6ab2d1cbca4d3/1586864301196/O-RAN+Use+Cases+and+Deployment+Scenarios+Whitepaper+February+2020.pdf>

[3]

Industry Leaders Launch ORAN Alliance, NTT DOCOMO, INC., February 27 2018, available at [https://www.nttdocomo.co.jp/english/info/media\\_center/pr/2018/0227\\_00.html](https://www.nttdocomo.co.jp/english/info/media_center/pr/2018/0227_00.html)

[4]

Mobile industry leaders to develop O-RAN fronthaul-compliant products and drive multi-vendor radio access networks, NTT DOCOMO, INC., February 22 2019, available at [https://www.nttdocomo.co.jp/english/info/media\\_center/pr/2019/0222\\_00.html](https://www.nttdocomo.co.jp/english/info/media_center/pr/2019/0222_00.html)

[5]

DOCOMO to Commence Deployment of World's First 4G/5G Multi-vendor Radio Access Network Conforming to O-RAN Specifications Facilitates multi-vendor interoperability, which will drive expansion of 5G coverage, NTT DOCOMO, INC., September 18, 2019, available at [https://www.nttdocomo.co.jp/english/info/media\\_center/pr/2019/0918\\_00.html](https://www.nttdocomo.co.jp/english/info/media_center/pr/2019/0918_00.html)

[6]

DOCOMO, Fujitsu and NEC Achieve World's First Carrier Aggregation Using 5G Frequency Bands on Multi-Vendor Radio Access Network Will allow 4.2Gbps downlink speed for high-speed data communications, NTT DOCOMO, INC., September 30 2020, available at [https://www.nttdocomo.co.jp/english/info/media\\_center/pr/2020/0930\\_00.html](https://www.nttdocomo.co.jp/english/info/media_center/pr/2020/0930_00.html)

[7]

Expanded Lineup of 5G Base Stations using O-RAN Specifications, NTT DOCOMO, INC., September 30 2020, available at [https://www.nttdocomo.co.jp/english/info/media\\_center/pr/2020/0930\\_01.html](https://www.nttdocomo.co.jp/english/info/media_center/pr/2020/0930_01.html)

[8]

Creation of "5G Open RAN Ecosystem" to Accelerate Open RAN to Operators Globally, NTT DOCOMO, INC., February 3 2021, available at [https://www.nttdocomo.co.jp/english/info/media\\_center/pr/2021/0208\\_00.html](https://www.nttdocomo.co.jp/english/info/media_center/pr/2021/0208_00.html)

[9]

What is the Cognitive Foundation?, NTT Corporation, available at <https://www.rd.ntt/e/iown/0004.html>



[10]

The O-RAN ALLIANCE Security Task Group Tackles Security Challenges on All O-RAN Interfaces and Components, blog, October 2020, O-RAN ALLIANCE, available at <https://www.o-ran.org/blog/2020/10/24/the-o-ran-alliance-security-task-group-tackles-security-challenges-on-all-o-ran-interfaces-and-components>

[11]

Securing Open, Virtualized Radio Access Networks, whitepaper, February 2021, wenvator LLC. , available at <https://www.wenvator.com/open-vran-security>

## **8. Annex A**

The following inputs were provided from OREC participating companies regarding their views on open RAN and vRAN as well as their expectations for these ecosystems. They are captured in alphabetical order of their names.

### **Dell Technologies Japan Inc.**

Dell Technologies is excited to be part of the OREC initiative as an ecosystem partner for the telecommunications industry.

In close collaboration with other cutting-edge technology vendors, we will develop highly reliable solution stacks pre-validated from a network operators' perspective to contribute to the global telecommunications industry. We believe we can help drive NTT DOCOMO's 5G strategy in terms of TCO reduction for RAN equipment, acceleration of RAN innovation through automation/cloudification and new 5G service creation. We will also leverage our sophisticated network of global supply chain to take the jointly created solutions to the global market. We are committed to working closely with NTT DOCOMO and other OREC ecosystem partners to deliver carrier-grade servers and solutions that are open, scalable, flexible and easily deployable as well as shock/extreme temperature-tolerant to meet the specific needs of RAN use cases while reducing physical footprint, with the end goal of contributing to the evolution and commercialization of Open RAN jointly with NTT DOCOMO and its ecosystem partners.

### **Fujitsu Limited**

The trend of 5G mobile network, virtualization and shift to software such as adaptation of vRAN, will be further accelerated in order to flexibly respond to constantly changing market needs that reflects diverse end-user requirements.

These inevitable changes means more complication in network components management, causing mobile operators to face huge challenges in RAN optimization and operational efficiency. The key technology to solve those challenges is automation such as RAN Intelligent Controller (RIC). By implementing these technologies into standard O-RAN Alliance compliant interfaces, mobile operators can quickly resolve operational challenges. It also contributes to further activate and expand the overall Open RAN market.

By combining its many years of experience and mobile network technology cultivated through R&D with the leading-edge technologies from OREC partners, Fujitsu is committed to continue to collaborate with OREC to provide open and intelligent next-generation mobile network for NTT DOCOMO as well as many other mobile operators around the world.

### **Intel K.K.**

Intel is playing a key role as a trusted partner to drive innovation and bring the full benefits of 5G to reality. Today, the industry has hit a tipping point with over half of core network workloads virtualized, and a tremendous momentum to virtualize the Radio Access Network (RAN).

Intel is at the forefront of this global transformation, powering nearly all early commercial virtualized RAN (vRAN) deployments and collaborating with service providers, equipment manufacturers and software vendors. With a combination of Intel® Xeon Scalable® processors, FPGAs, eASIC accelerators, Ethernet adapters and Intel's FlexRAN software reference architecture, the industry is choosing to build on Intel's complete set of network technology solutions. These advancements are critical steps toward realizing the full potential of 5G, edge and artificial intelligence outcomes across a range of industries, including retail, education, healthcare and more.

### **Mavenir**

<https://www.mavenir.com/resources/openran-mature-and-ready-for-deployment/>

### **NEC Corporation**

Open and virtualized architecture is becoming the main stream in the telecom industry, which happened on IT industry in the past.

While open architecture brings innovation and flexibility, ensuring an inter-operability is one of big challenges for service providers. NEC is best positioned as Open Ecosystem enabler to address such challenge through lots of experiences in an end-to-end system integration testing under multi-vendor environment for Tier-1 operators. NEC leads the market with innovative technologies and contributes to the evolution of cloud-based network infrastructure from SDN/NFV era. We had developed the world's first virtualized evolved packet core in the past. And now we are delivering the 5G cloud-native mobile core based on our expertise on cloudification, bringing more values such as faster time-to-market, greater flexibility and scalability. NEC is excited to contribute to this initiatives based on our accumulated expertise in an open and virtualized network architecture.

### **NTT DATA Corporation**

Accumulate and systematize integration know-how in a multi-vendor environment, which is one of the issues when introducing open RAN. We hope that 5G Open RAN Ecosystem promotes the spread of open RAN.

## **NVIDIA**

Open RAN runs on commercial off-the-shelf servers efficiently-accelerated, programmable, cloud-native and AI-ready at very well optimized TCO - these characteristics are fundamental principles that we share with 5G Open RAN Ecosystem.

NVIDIA will be working with DOCOMO and EcoSystem partners to realize them by means of Aerial A100, the next-gen GPU/DPU converged accelerator and comprehensive SDKs & fine-tuned software frameworks for 5G as well as AI and Security.

## **Qualcomm Technologies, Inc.**

5G virtualized RAN aims to enable innovative, high-performance and interoperable 5G networks at scale, while reshaping mobile experiences and allowing for cost effective global 5G mmWave and Sub-6 deployments. It is a pleasure to continue our work with DOCOMO to accelerate Open RAN adoption and transition to modern 5G networks through Qualcomm Technologies' portfolio of 5G RAN solutions.

## **Red Hat**

Red Hat joined O-RAN alliance from CRAN (cloud RAN) alliance which established O-RAN alliance together with xRAN forum, in 2018. Our primary focus area in O-RAN alliance is Kubernetes Native Infrastructure base O-Cloud. By leveraging Operator Framework technology, we are helping to integrate Hardware performance oriented 5G RAN devices on COTS server. Our mission in OREC is to help package best-of-breed Open RAN in which disaggregated network computing with decoupling hardware and software. As you know, Red Hat is one of top contributors for OpenStack NFV platform to support mature NFV architecture. Another mission together with OREC members is to harmonize Kubernetes base CNF style operation for disaggregated computing and OpenStack base NFV style operation for virtualization. O-Cloud deployment management system must have one or more O2 interfaces such as O2-Kubernetes plugin and O2-OpenStack plugin. We help to create Open flexible solutions that many operators in many countries can select from the OREC package based on each innovation pace.

## **VMware K.K.**

Founded on a legacy of cloud and virtualization excellence and driven by a mission to enable multi-vendor, multi-cloud agility, VMware is proud to work with NTT DOCOMO and our ecosystem partners to support the 5G Open RAN Ecosystem. Together, we will help disaggregate and modernize the RAN to decrease costs and spur innovation and monetization.

### **Wind River**

With growing interest in 5G Open RAN, the industry is working towards a vision of improved efficiency of RAN deployments and operations, with faster innovation and where networks components can work seamlessly from a mix of suppliers. Virtualization is the foundation of this transformation, and Wind River has been contributing capabilities such as distributed cloud-native solutions unifying infrastructure, orchestration, and analytics so that operators can deploy and manage their intelligent, distributed 5G edge networks globally at high scale. Working together with the NTT DOCOMO 5G Open RAN Ecosystem program, we are encouraged by the progress of the group to enable greater levels of network flexibility and agility.

### **Xilinx, Inc.**

Joining forces with other leaders (NEC, Dell, Red Hat) under the leadership of NTT DOCOMO for this OREC ecosystem is important for the O-RAN market. It is a critical effort to enable integration, interoperability, from an end to end solution level and offer complete flexible O-RAN configurations pre-validated so that worldwide operators can test their own use cases. From Xilinx perspective, our Telco Acceleration card is the cornerstone cord between the O-RU and the O-DU. We expect the OREC to be able to demonstrate a strong improvement on the TCO for the end to end O-DU solution with Xilinx FPGA based acceleration card, including performance improvement (L1 Offload) as well as freeing up CPUs for Operators to add value services. Ecosystem Integration with Red Hat OPENSIFT, along with NEC 5G Software stack, Dell Hardware are important other steps in this OREC activity.

## 9. Annex B. Abbreviations

3GPP	3rd Generation Partnership Project
AAL	Abstraction Layer
AI	Artificial Intelligence
AMOR	Automated Monitoring, Response and Operations
API	Application Programming Interface
ASIC	Application Specific Integrated Circuit
CA	Carrier Aggregation
CAPEX	Capital Expenditure
CI/CD	Continuous Integration/Continuous Delivery
CN	Core Network
COTS	Commercial Off-The-Shelf
CPU	Central Processing Unit
CSP	Communication Service Provider
CU	Central Unit
DC	Data Center
DevOps	Development and Operations
DL	Downlink
DU	Distributed Unit
EM	Element Management
eNB	4G LTE base station
ETSI	European Telecommunications Standards Institute
FPGA	Field-Programmable Gate Array
gNB	5G NR base station
GPU	Graphics Processing Unit
HLS	Higher Layer Split
HW	Hardware
IAM	Identity & Access Management
ICT	Information and Communication Technology
IOT	Interoperability Testing
IOWN	Innovative Optical and Wireless Network
IT	Information Technology

MANO	Management and Network Orchestration
MEC	Multi-access Edge Computing
MIMO	Multiple Input Multiple Output
ML	Machine Learning
NFV	Network Functions Virtualization
O&M	Operation and Maintenance
OPEX	Operating Expenditure
OREC	5G Open RAN Ecosystem
OSS	Operation Support System
OTIC	Open Test and Integration Center
PAM	Privileged Access Management
PoC	Proof of Concept
RAN	Radio Access Network
RIC	RAN Intelligent Controller
RT	Real-Time
RU	Radio Unit
SLA	Service Level Agreement
SMO	Service Management and Orchestration
SU	Single User
SW	Software
TCO	Total Cost of Ownership
UL	Uplink
UPF	User Plane Function
vCU	virtualized CU
vDU	virtualized DU
vRAN	virtualized RAN